

2"-4 1/2"
O.D.

114 SERIES

- Features :*
- Overlapping rolls prevent ridging of tube.
 - Can be converted for parallel expansion use - enquire with us.
 - Self retained rolls in cage.
 - Compact design for use through small handholes, headers etc.
 - Use - General purpose expander for expanding and flaring boiler tubes, water wall, downcomer, economizer, riser and air heater tubes.

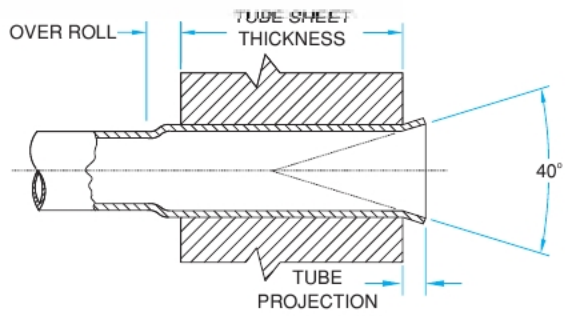

Tube O.D.	Tube Thickness		Tube O.D.	Tube Thickness		Minimum I.D. Tool Enters		Maximum Expansion Of Tool		Tube Expander Model Number Tube Sheet Thickness Range				
	inch	bwg		inch	bwg	inch	mm	inch	mm	inch	1/2" To 7/8"	3/4" To 1.1/8"	1.1/8" To 1.5/8"	1.5/8" To 2.1/8"
2	4 & 5	.238 & .220	1.3/4	11 - 13	.120 - .095	36.7	1.444	43.1	1.696	-	14172	14174	14176	14178
2	6 & 7	.203 & .180	1.3/4	14 - 16	.480 - .065	38.3	1.507	44.6	1.755	-	14182	14184	14186	14188
2	7 & 8	.180 & .165				39.9	1.570	46.4	1.826	14191	14192	14194	14196	14198
2	9 & 10	.148 & .134	2.1/4	13	.095	41.5	1.633	48.0	1.889	14201	14202	14204	14206	14208
2	11 - 13	.120 - .095	2.1/4	4 & 5	.238 & .220	43.1	1.696	49.6	1.952	14211	14212	14214	14216	14218
2.1/2	2	.284	2.1/4	6 - 8	.203 - .165	45.5	1.791	52.6	2.070	-	14222	14224	14226	14228
2.1/2	3 & 4	.259 & .238	2.1/4	9 - 11	.148 - .120	47.1	1.856	54.2	2.133	-	14232	14234	14236	14238
2.1/2	4 - 6	.238 - .203	2.1/4	12 - 15	.109 - .072	49.0	1.929	57.3	2.255	-	14242	14244	14246	14248
2.1/2	7 - 10	.180 - .134	2.3/4	2 & 3	.284 & .259	51.9	2.043	60.5	2.381	-	14252	14254	14256	14258
2.1/2	11 - 13	.120 - .095	2.3/4	4 & 5	.238 & .220	55.1	2.169	63.7	2.507	14261	14262	14264	14266	14268
3	1 - 3	.300 - .259	2.3/4	6 - 10	.203 - .134	57.4	2.259	66.6	2.622	-	14272	14274	14276	14278
3	4 - 6	.238 - .203	2.3/4	11 - 15	.120 - .072	60.6	2.385	70.0	2.755	-	14282	14284	14286	14288
3	7 - 11	.180 - .120	3.1/4	1 - 4	.300 - .238	63.8	2.511	73.9	2.909	-	14292	14294	14296	14298
3	10 - 12	.134 - .109	3.1/4	4 - 7	.238 - .180	66.9	2.635	77.3	3.043	14301	14302	14304	14306	14308
3.1/2	1 - 4	.300 - .238	3.1/4	7 - 11	.180 - .120	70.1	2.759	80.1	3.153	-	14312	14314	14316	14318
3.1/2	4 - 7	.238 - .180	3.1/4	10 - 15	.134 - .072	73.0	2.874	83.4	3.283	-	14322	14324	14326	14328
3.1/2	7 - 11	.180 - .120	3.3/4	2 & 3	.284 & .259	76.2	3.000	86.8	3.417	-	14332	14334	14336	14338
3.1/2	10 - 12	.134 - .109	3.3/4	4 & 5	.238 & .220	79.3	3.122	89.8	3.535	-	14342	14344	14346	14348
4	1 - 4	.300 - .238	3.3/4	6 - 10	.203 - .134	82.5	3.248	93.0	3.661	-	14352	14354	14356	14358
4	4 - 7	.238 - .180	3.3/4	11 - 15	.120 - .072	85.7	3.374	96.0	3.779	-	14362	14364	14366	14368
4	7 - 11	.180 - .120	4.1/4	2 & 3	.284 & .259	88.9	3.500	98.6	3.881	-	14372	14374	14376	14378
4	8 - 12	.165 - .109	4.1/4	3 & 5	.259 & .220	90.5	3.562	102.3	4.027	-	14382	14384	14386	14388
4.1/2	1 - 4	.300 - .238	4.1/4	6 - 9	.203 - .148	95.2	3.748	104.7	4.122	-	14392	14394	14396	14398
4.1/2	3 - 8	.238 - .165	4.1/4	10 - 13	.134 - .095	98.4	3.874	110.3	4.342	-	14402	14404	14406	14408
4.1/2	6 - 12	.203 - .109	-	-	-	101.6	4.000	113.5	4.468	-	14412	14414	14416	14418

114 SERIES

2" - 4 1/2"
O.D.

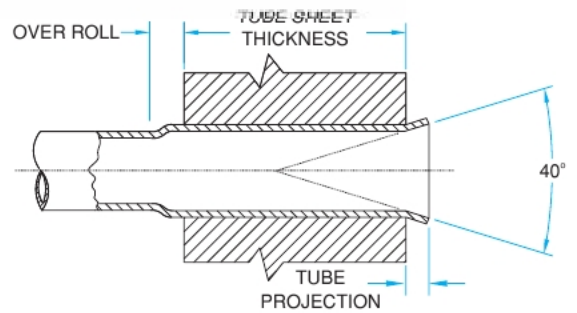

Spare Rollers Set Model Number Tube Sheet Thickness Range					Mandrel Square Drive Size inch	Drum Type	Header Type	Spare Mandrel Model Number						
1/2" To 7/8"	3/4" To 1.1/8"	1.1/8" To 1.5/8"	1.5/8" To 2.1/8"	2.1/8" To 2.5/8"				Short Series 5.1/8 inch			Short Series 7.1/8 inch			
-	34872	34874	34878	34948	3/4	32269	32289	32308	32309	32310	32311	34876, 34948		
-	34879	34881	34883	34949	3/4	32269	32289	32309	32310	32311		-		
34878	34879	34881	34883	34949	3/4	32270	32290	32309	32310	32311	32312	-		
34878	34879	34881	34883	34949	3/4	32271	32291	32311	32312	32313		32346		
34885	34886	34888	34890	34950	3/4	32270	32290	32310	32311	32312		32345		
-	34893	34895	34897	34951	3/4	32270	32290	32310	32311	32312	32313	-		
-	34893	34895	34897	34951	3/4	32271	32291	32311	32312	32313	32314	-		
-	34893	34895	34897	34951	3/4	32272	32292	32312	32313	21214	32315	32316	-	
-	34900	34902	34904	34952	3/4	32272	32292	32312	32313	32314	32315	32316	32347 32348 32349	
34899	34900	34902	34904	34952	3/4	32273	32293	32315	32316	32317		33630 33631		
-	34907	34909	34911	34953	3/4	32273	32293	32315	32316	32317	32318	32319	-	
-	34907	34909	34911	34953	1	32274	32294	32317	32318	32319	32320	32321	-	
-	34914	34916	34918	34954	1	32274	32294	32318	32319	32320	32321	32322	33632 33633 33634 33635	
34913	34914	34916	34918	34954	1	32275	32295	32320	32321	32322		33634 33635		
-	34921	34923	34925	34955	1	32274	32294	32318	32319	32320	32321	32322	-	
-	34921	34923	34925	34955	1	32275	32295	32321	32322	32323	32324	32325	-	
-	34921	34923	34925	34955	1	32276	32296	32323	32324	32325	32326	32327	-	
-	34921	34923	34925	34955	1	32277	32297	32324	32325	32326	32327	32328	-	
-	34928	34930	34932	34956	1	32276	32296	32324	32325	32326	32327	32328	-	
-	34928	34930	34932	34956	1	32277	32297	32326	32327	32328	32329	32330	-	
-	34928	34930	34932	34956	1	32278	32298	32328	32329	32330	32331	32332	-	
-	34935	34937	34939	34957	1	32277	32297	32324	32325	32326	32327	32328	-	
-	34935	34937	34939	34957	1	32278	32298	32329	32330	32331	32332	32350	-	
-	34935	34937	34939	34957	1	32279	32299	32331	32332	32350	32337	32338	-	
-	34942	34944	34946	34958	1	32278	32298	32326	32327	32328	32329	32330	-	